

FloorMac 300
Machine base

As at: 05/28/08 Time:01:56

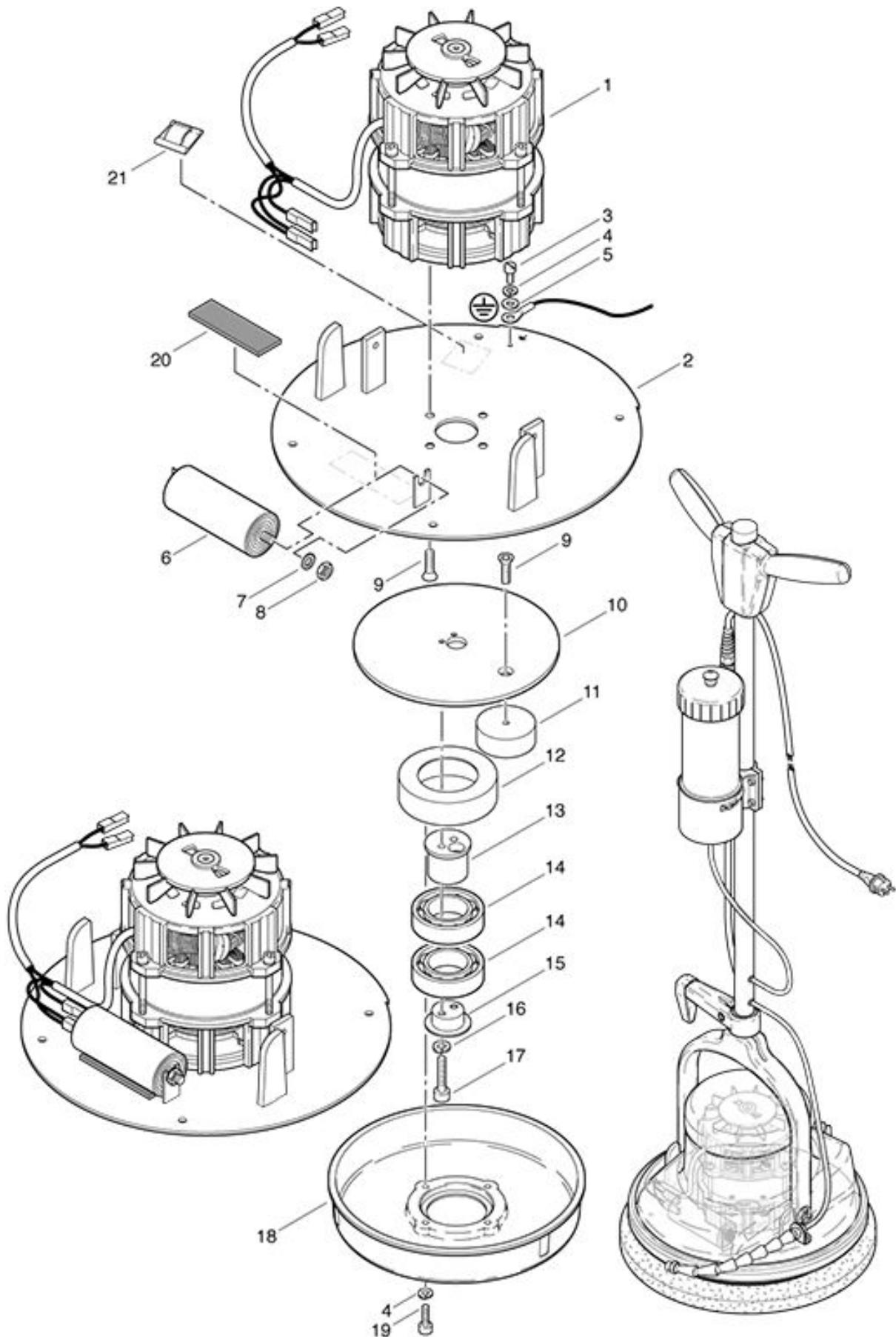

FloorMac 300

Machine base

As at: 05/28/08 Time:01:56

Pos.	Description		Reference
01	Motor complete	230 V/ 50 Hz	718.121
02	Base plate compl.		718.130
03	Chees-head screw 4 x10		P...478 C
04	Spring washer M 4		P...498 C
05	Washer M 4		P...497 D
06	Capacitor 12 µF		718.124
07	Lock washer M 8		6610419
08	Hexagon screw M 8		P...491 F
09	Countersunk screw M 6x20		P...480 H
10	Driving plate to counter weight		718.141
11	Counter weight		718.142
12	Bearing flange		718.146
13	Excentric		715.148
14	Ball bearing		6426437
15	Excentric cover		718.147
16	Spring washer M 5		P...500 D
17	Hexagon screw M 5x25		P...488 K
18	Driving plate		718.120
19	Hexagon screw M 4x12		P...486 A
20	Slide security		400.139
21	Cable support		P...360