

Home-Cleaner Pump

As at: 05/24/08 Time:06:34

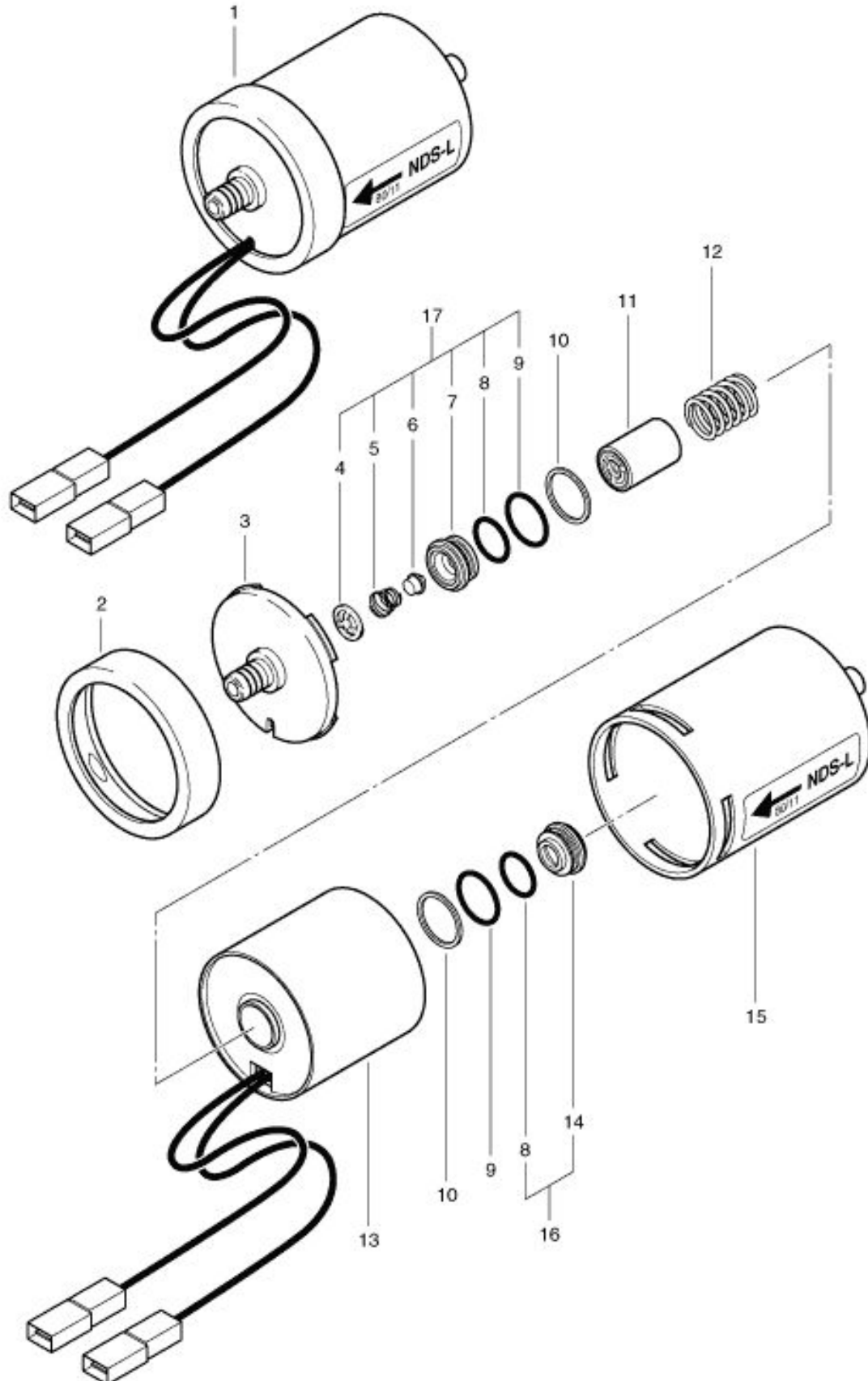

Home-Cleaner Pump

As at: 05/24/08 Time:06:34

Pos.	Description		Reference
01	NDS-L - pump	220-240V 50Hz	P...815
01.	NDS-L - pump	24V DC	P...815 L
02	Ring		P...815 H
03	Cover		P...815 B
04	Counter ring		P...809 N
05	Valve spring		P...809 P
06	Valve cone		P...810 S
07	Valve seating		P...809 Q
08	O-ring 12x1,5 mm		P...809 L
09	O-ring 14x1,5 mm		P...809 K
10	Counter ring		P...815 X
11	Piston		P...809 B
12	Pressure spring for piston		P...809 E
13	Housing pipe		P...815 D
14	Spring support		P...809 F
15	Raising NDS-L		P...815 A
16	Spring support compl. Including: items 8+14		P...811 X
17	Valve seating compl. Including: items 4-9		P...811 Y