

TW 300 S Pump

As at: 05/12/08 Time:20:21

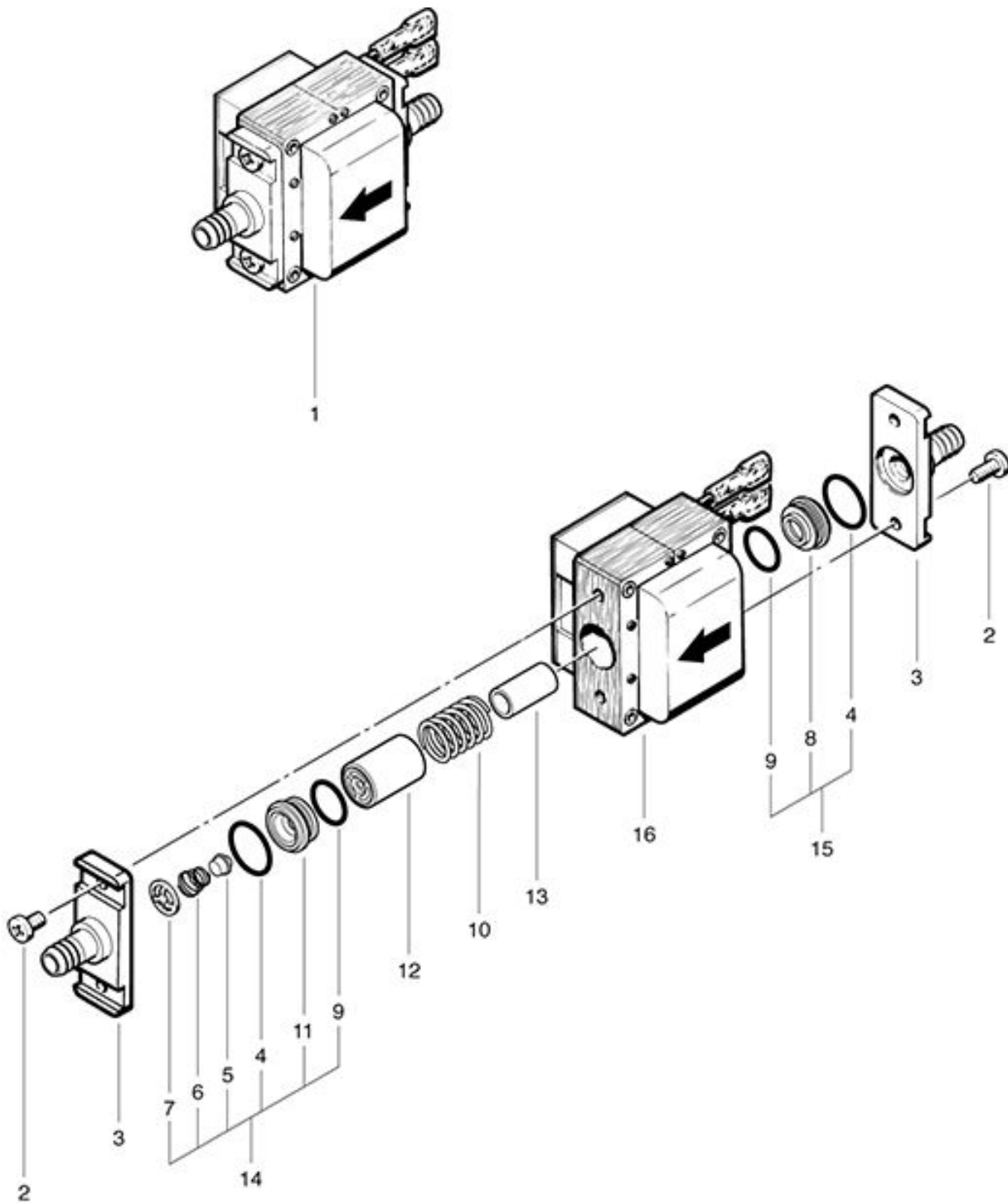

TW 300 S

Pump

As at: 05/12/08 Time:20:21

Pos.	Description	Reference
01	NDS-X-pump 220-240V/50Hz	P...809
02	Raised head screw M 4	P...481 M
03	Hose connection	P...809 M
04	O-Ring Ø 14 mm	P...809 K
05	Valve cone	P...810 S
06	Valve spring	P...809 P
07	Counter ring	P...809 N
08	Spring support	P...809 F
09	O-ring Ø 12 mm	P...809 L
10	Piston spring	P...809 E
11	Valve seating	P...809 Q
12	Piston	P...809 B
13	Distance piece	P...809 S
14	Valve seating compl. Including: items 4-7, 9+11	P...810 Y
15	Spring support compl. Including: items 4,8+9	P...810 X
16	Magnet coil 230 V/50 Hz	P...809 A