

TW 300 S
Wiring plan

As at: 05/12/08 Time:20:24

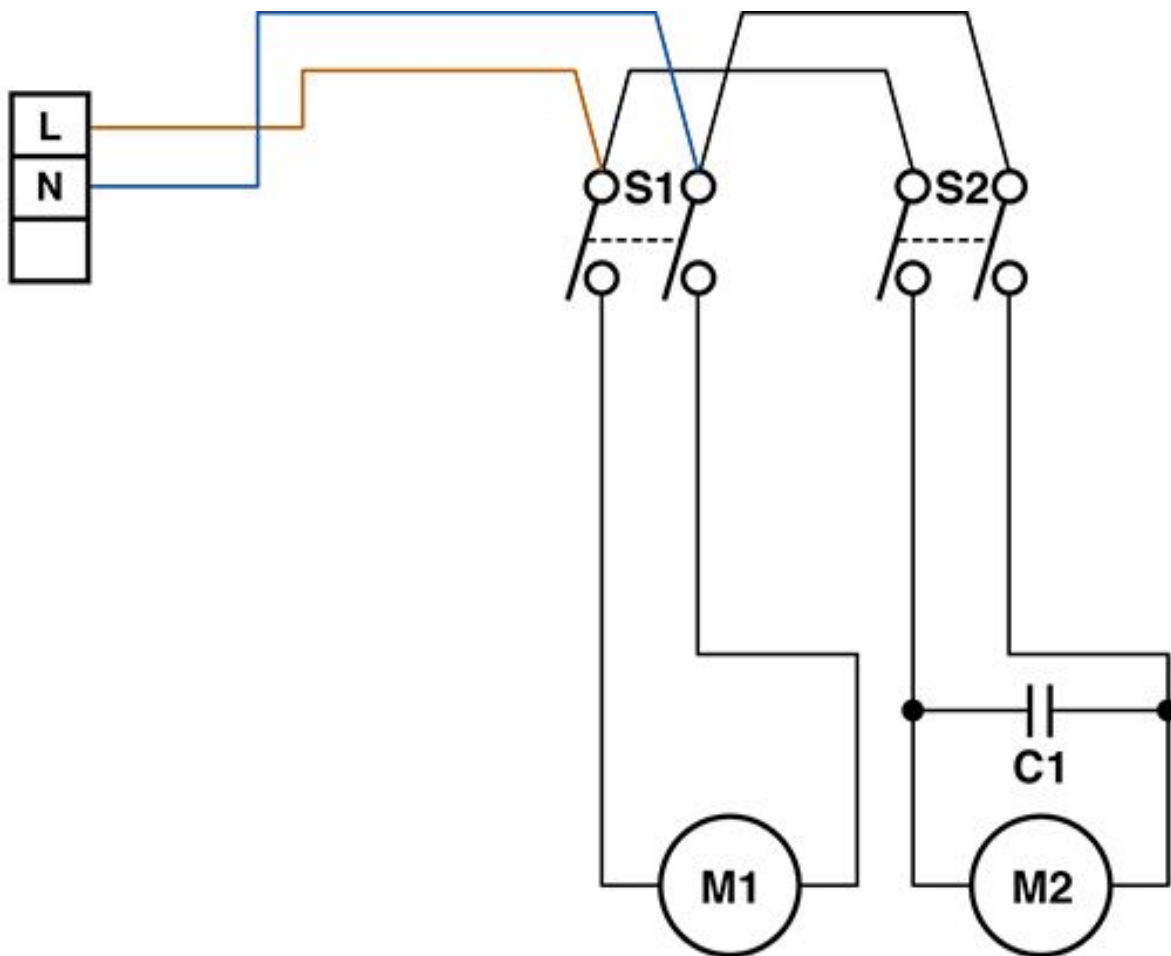

- S1 = Schalter 1 / Interrupteur 1 / Tumbler switch 1
- S2 = Schalter 2 / Interrupteur 2 / Tumbler switch 2
- C1 = Entstörkondensator 0,1 F / Condensateur 0,1 F / Capacitor 0,1 F
- M1 = Pumpe / Pompe / Pump
- M2 = Saugmotor LAMB, 750 W / Motuer d'aspiration 750 W, LAMB / Vacuum motor 750 W, LAMB
- M2 = Saugmotor OEP, 1000 W / Motuer d'aspiration 1000 W, OEP / Vacuum motor 1000 W, OEP

TW 300 S

Wiring plan

As at: 05/12/08 Time:20:24

Pos.	Description	Reference
C1	Condensator 0,15 μ F	P...391
M1	Pump	P...809
M2	Vaccum motor LAMB, 750 W	P...870 H
M2	Vaccum motor OEP, 1000 W	P...870 B
S1	Switch 1	P...240
S2	Switch 2	P...240